

AMB20 MANUAL

For RC Model Cars and Rental Karts

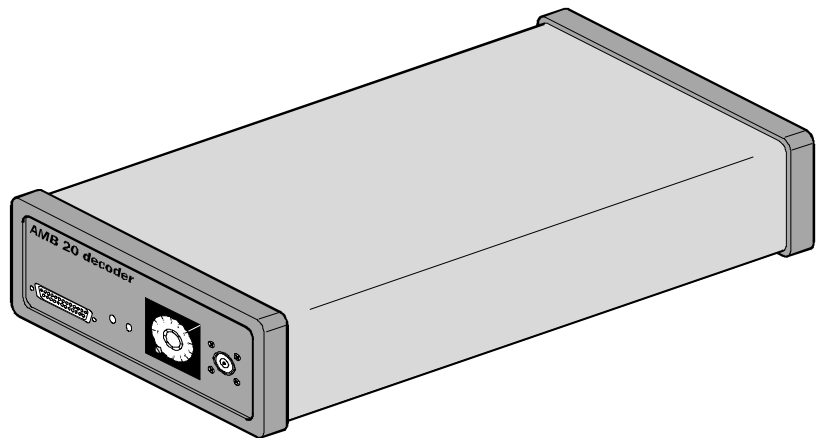
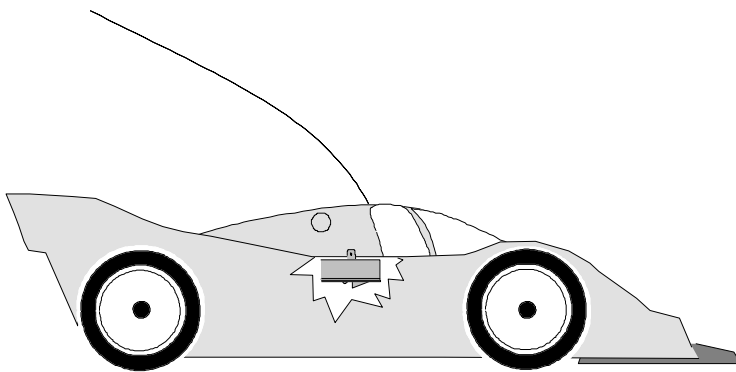

The AMB20 system is specially designed to time/score radio controlled electric and gas driven model cars and rental karts. The signal sent by an AMB20 transponder that is mounted on a RC model car or kart, is picked up by the detection loop which is installed in the track. This detection loop is connected to the AMB20 decoder. The decoder timestamps the received transponder signals and sends this data via an RS232 cable to a connected computer. The decoder is powered by a 12V mains adapter, the transponder is powered by a rechargeable battery.

Contents

1. COMPONENTS OF THE SYSTEM	3
2. INSTALLATION OF THE DETECTION LOOP	4
3. INSTALLATION OF THE AMB20 DECODER	6
4. INSTALLATION OF THE TRANSPONDER IN A RC MODEL CAR.....	7
5. INSTALLATION OF THE TRANSPONDER ON THE KART.....	8
6. CHARGING THE TRANSPONDER	9
7. OPERATING THE SYSTEM / TROUBLE SHOOTING	10
8. TECHNICAL SPECIFICATIONS.....	12
9. EC AND FCC REGULATIONS	13



AMB i.t. B.V.

Manual number: AMB20/Rev.02

All rights reserved

This publication is to be used for the standard model of the product of the type given on the cover page. This publication has been written with great care. However, the manufacturer cannot be held responsible, either for any errors occurring in this publication or for their consequences.

Supplied by AMB Transponder repairs - Australia
<http://users.bigpond.net.au/bigfix/transponders>

Page 2 of 13

1. Components of the System

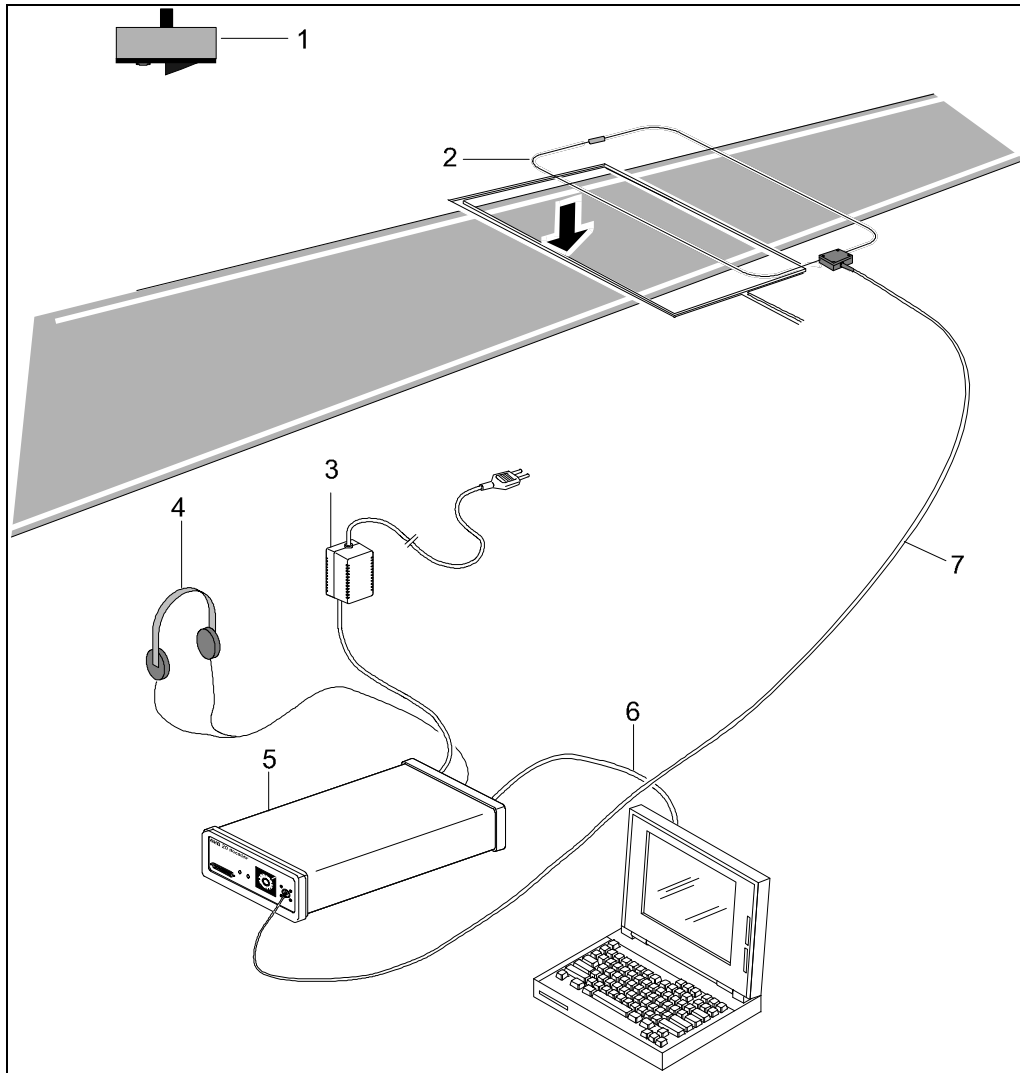

- | | |
|---|-----------------------------------|
| 1. AMB20 transponder (1221/1222/1223) | 5. AMB20 decoder (3201/3202) |
| 2. Detection loop (4201/4202) | 6. Connection cable RS232 (6201) |
| 3. Adapter for AMB decoder (6501/6502) | 7. Coax cable (part of 4201/4202) |
| 4. Headphones for decoder (optional) (6701) | |

2. Installation of the Detection loop

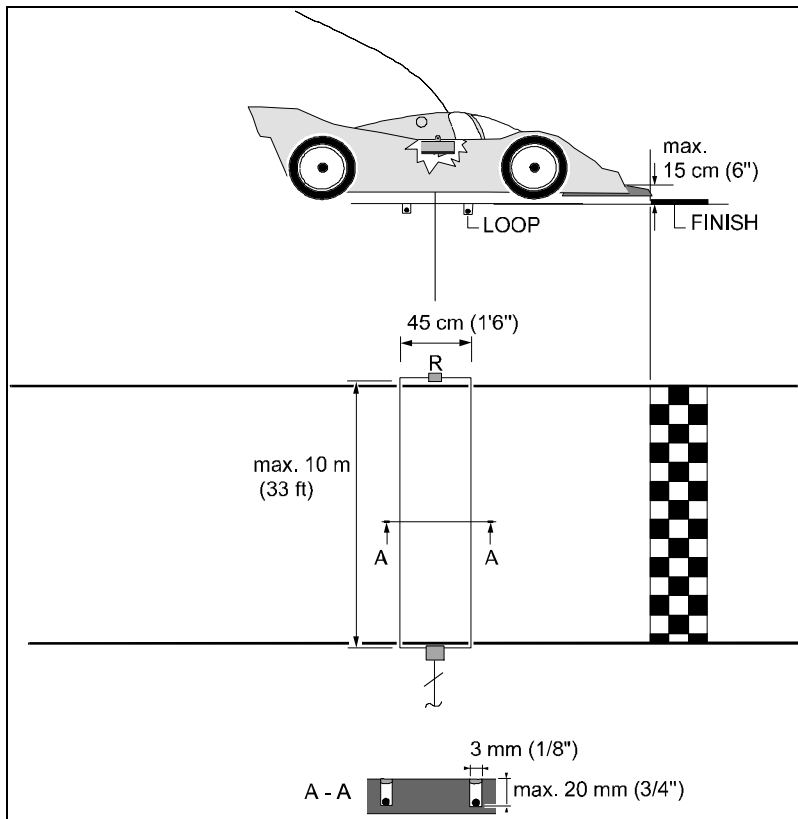

1. The detection loop must be positioned in such a way that the transponder is in the middle above the detection loop when the front of the RC model car or kart is above the finish line.
2. Cut the slots in the track maximum 2 cm / 3/4" deep and 45 cm / 1'6" apart. Make sure vehicles can not pass outside the detection loop. Extend the detection loop outside the track if necessary.
3. Put the wires of the detection loop in the slots and cut the excess length of the detection loop wires.
4. Put the heat shrinkage sleeves over one of the detection loop wire ends. Solder the 470 Ohm resistor between the two ends of the detection loop wire. Put both the shrinkage sleeves over the resistor and hold it over a heat source.
5. Fill the slot with silicon. Make sure the silicon is fully under the surface of the track, otherwise the tires may pull out the silicone. For OFF-ROAD use cover the loop with carpet or similar. Carpet can be covered with sand etc.
6. The detection loop is sensitive to interference, possibly emitted by nearby cables. When possible keep all cables 3 m / 10 ft away. Also make sure RC model cars or karts on

other parts of the track can not get closer than 60 cm / 2 ft from the detection loop, to avoid false inputs.

7. All wiring of the loop must be installed according to the drawing in order to avoid a serious degradation in performance.

3. Installation of the AMB20 decoder

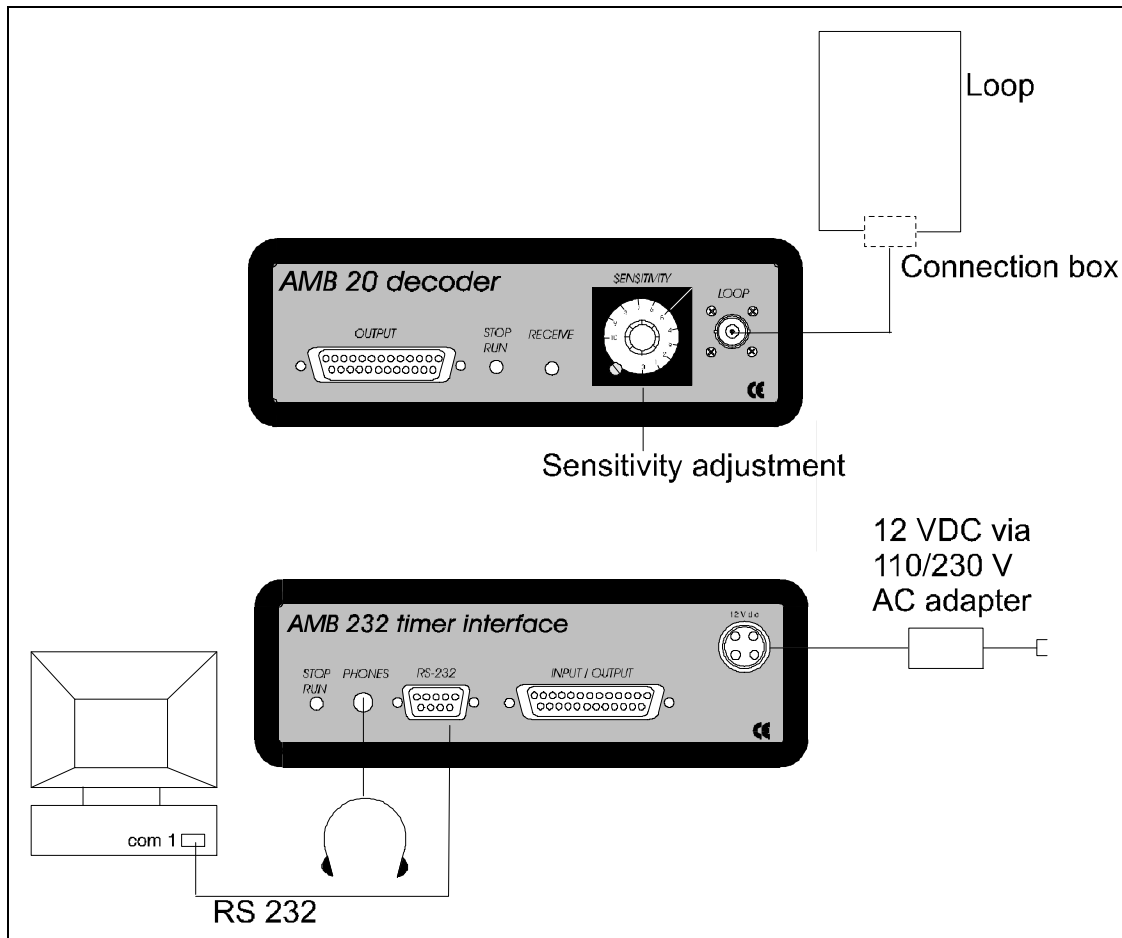

1. The decoder is a precision instrument. It is designed to withstand shocks but please handle it with care and keep the decoder out of direct sunlight.
2. Connect the 75 Ohm double shielded coax cable to the AMB20 decoder. Keep the coax cable at least 30 cm / 1 ft away from other cables to avoid interference.
3. Initially set the sensitivity adjustment to 5.
4. Connect the RS232 cable between the AMB232 timer interface (rear side of the decoder) and the RS232 port of the computer and connect the headphone. A beep will sound for every passing transponder.
5. Connect the 12V adapter to the decoder and mains.

Note: Make sure the correct version of the decoder is used in respect to the transponder numbers. Transponder no. 14 can not be detected by a decoder version 1-10. The decoder version is indicated on the label at the underside of the decoder.

4. Installation of the transponder in a RC model car

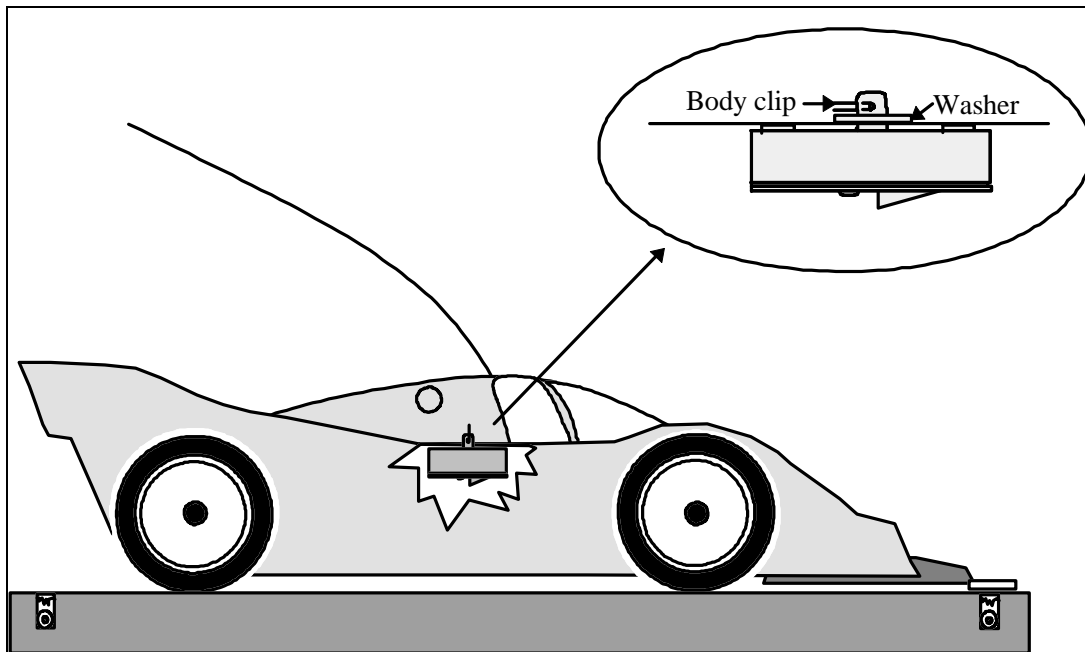

The transponder must be mounted horizontally, preferably inside the RC model car against the side, with the fixing pin pointing upwards or downwards. The position of the transponder must be identical in all RC model cars competing in the race.

Put a washer around the fixing pin and fix the transponder with a fixing clip. Transponders may not be placed higher than 15 cm / 6'' above the track, with no metal or carbon fiber beneath it. Make sure the transponder can not get detached during a race.

For OFF-ROAD RC model cars, the transponder may be fixed underneath the rear wing of the RC model car.

5. Installation of the transponder on the kart

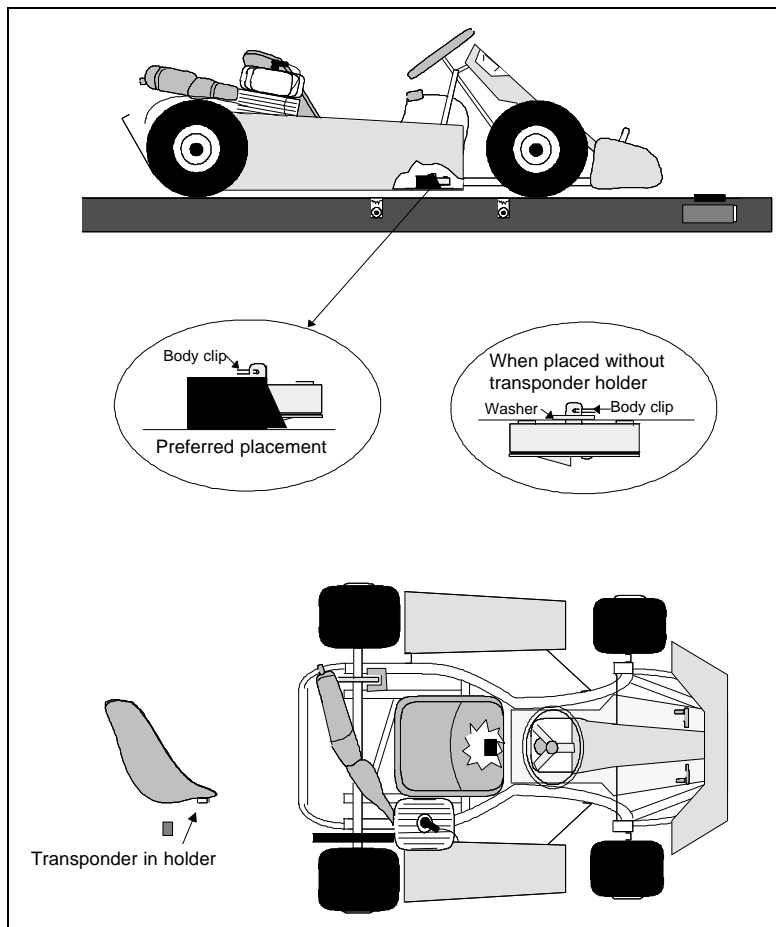

The transponder must preferably be fitted in a transponder holder and fixed in the holder with help of the supplied metal clip. If the transponder holders are not used, a washer must be put around the fixing pin under the clip in order to assure a proper fixing of the transponder on the kart.

The transponder must be mounted horizontally on the kart, preferably inside the right side pot, with the fixing pin pointing upwards or downwards. The position of the transponder must be identical on all karts competing in the race. Transponders may not be placed higher than 15 cm / 6" above the track, with no metal or carbon fiber beneath it.

The transponder holders are permanently fixed on the kart using tie-wraps or 3M double sided tape (on smooth surfaces only). Make sure the transponder and transponder holder can not get detached during a race.

6. Charging the transponder

When charged, the AMB20 transponder constantly emits its magnetic output signal. Battery capacity is sufficient for 30 hours of use.

Charging must be done in the AMB charger rack (article no. 2401), preferably at room temperature since NiCad cells do not charge well at temperatures below 14C. During charging, the green led in each transponder indicates charging.

The ratio between charge time versus use is about 1 in 2, so 8 hours charge give 16 hours use. Charging time for one day of use is 8 hours minimum.

Battery voltage can be measured on the charge contacts of the transponder with help of a digital voltmeter. 1,3 V or more indicates a full charge, 1,15 V indicates nearly empty. Voltage decrease is not linear with charge state. Short circuiting charge contacts of the transponder does not discharge the NiCad cell nor does it affect its proper functioning.

Warning: Airline regulations demand all electronics to be switched-off when on board of a plane. The AMB20 transponders switch themselves off when the NiCad cells are empty. When airline travel is expected after a race event, do not charge longer than necessary to proceed with the races.

The transponder switches on as soon as re-charging starts.

7. Operating the system / Trouble shooting

Led indications

When switched-on the decoder performs a self test, which shows by blinking of the STOP/RUN led (red/green). The actual timing is started and stopped by the software or by an external start pulse (must be supported by the software, also see technical specifications). If the STOP/RUN led shows green, the decoder is ready to time each passing transponder. Each time the decoder receives a transponder signal the RECEIVE led shows green. After the decoder is stopped, the STOP/RUN led shows red.

Sensitivity adjustment

The initial sensitivity setting is 5. The sensitivity must not be set higher than necessary, to avoid input overload. If the sensitivity is set too low this shows by a reduced and varying number of hits of passing transponders.

Interference

Strong interference, indicated by the RECEIVE led showing red, can severely reduce the number of hits per passing. Most interference is caused by (modified) speed controllers of RC model cars, any electrical switch in the area or, usually at night, by short-wave radio stations. Electronic equipment may also cause interference. Switch-off the suspected equipment to find out.

Hits

The hit-rate, as shown by the AMB software, is an indication of the number of repeated contacts during a passing. The hit-rate varies with the speed of a passing transponder and sensitivity setting. The hit-rate should preferably be higher than 10, but should not reach 50. When the hit-rate continuously exceeds 50, adjust the sensitivity setting to a lower value.

Back-up system

Since electronic timing and scoring has become an integral part of most RC model car and (rental) kart tracks all over the world, a second AMB20 system may serve as a back-up system (e.g. in case of an important event). The signal coming from the detection loop can be connected to both the decoders by using the AMB splitter (article no. 6704) and two short coax cables (2x article no. 6001) at the end of the coax cable. Another solution is to place a back-up system detection loop 2 m / 7 ft or more before the main detection loop and connect it separately to the second decoder.

Output connector

The output connector on the AMB20 decoder is used to interconnect an 1-10 version with an 11-20 version decoder, using a 25 pin connection cable (article no. 6211).

Problems

Most problems concerning the functioning of the system are due to bad connections or improper installation. Mobile phones and other forms of personal radio communications do not affect the AMB i.t. systems.

If you still have questions or problems, please contact AMB i.t. by fax or e-mail supplying the following data:

1. Description of the problem and the purpose the system was used for.
2. Decoder and transponder type and their serial numbers.

8. Technical Specifications

AMB20 Decoder

Dimensions	: 320x170x60 mm / approx. 13''x 7'' x 3''
Number of competitors	: 10 or 20, depending on the model
Timing resolution	: 0,01 sec
Clock Accuracy	: 20 ppm
Temp. range	: 0-50 °C / 32-122 °F
Humidity	: max. 90% relative
Power supply	: 12 VDC via 115/230 VAC adapter

RS232 Timer interface (rear side of the decoder)

External start pulse	: 6 - 24 V AC/DC on pin 22 (-) and pin 24 (+)
Output	: RS 232, 9600 baud, 8 bit, 2 stop-bits, no parity

AMB20 Transponder

Dimensions	: 35x31x12 mm / approx. 1¼''x1¼''x ½''
Weight	: 22 g
Humidity	: max. 90% relative
Max. speed	: 120 km/h / 75 mph.
Temperature range	: 0-50 °C / 32-122 °F
Operating time	: min. 30 hrs
Charge indicator	: LED indicator during charging
Signal transfer	: magnetic induction
Transponder position	: max. height 15 cm / 6''
Charging voltage	: 3,3 VDC

Transponder Charger

Dimensions	: 380x117x65 mm / approx. 15''x5''x3''
Capacity	: 20 transponders
Power supply	: 3,3 VDC via 115/230 VAC adapter

Detection Loop

Track width	: max. 10 m / 33 ft
Coax to decoder	: max. 100 m / 330 ft

Specifications are subject to change without notice

9. EC and FCC regulations

Most electronic equipment produces some undesired interference at a close distance. To make sure the increasing numbers of electronic equipment will not cause harmful interference, the CE (Europe) and FCC (US) regulations state very low levels of interference that should not be exceeded. The AMB equipment does not exceed these levels.

The CE regulations also state the levels of interference generated by other sources which the equipment must be able to tolerate without malfunctioning. These levels are considerably higher than the interference levels produced by the electronic equipment itself. Cellular telephones however may generate interference levels which may cause other electronic equipment to malfunction. AMB made sure its equipment is not sensitive to the interference generated by cellular telephones or other modern forms of personal radio communications.

The FCC regulations for Information Technology equipment which must be printed in the manuals state that you must tolerate interference produced by others and you must switch-off when interference produced by your equipment is experienced by others. The level of interference is strongly reduced when you increase the distance between two pieces of electronic equipment. For example: your portable radio will most probably experience interference when placed on top of your monitor, but will work very well a few feet away. Since the AMB transponders operate on magnetic induction they have no antenna, but a built-in coil instead. The transponders do not produce an electromagnetic (radio) wave but only a magnetic wave. The difference between an electromagnetic (radio) wave and a magnetic wave is that the electromagnetic wave travels by itself over great distances and the magnetic wave does not. As the distance increases the strength of the magnetic wave is greatly reduced. This is why AMB transponders are no transmitters.

This equipment complies with part 15 of the FCC rules. Operation is subject to the following two conditions: (1) This equipment may not cause harmful interference, and (2) this equipment must accept any interference received, including interference that may cause undesired operation.

Note: This equipment has been tested and found to comply with the limits for a Class B digital device, pursuant to part 15 of the FCC rules. These limits are designed to provide reasonable protection against harmful interference in a residential installation. This equipment generates, uses and can radiate radio frequency energy and, if not installed and used in accordance with the instructions, may cause harmful interference to radio communications. However, there is no guarantee that interference will not occur in a particular installation. If this equipment does cause harmful interference to radio or television reception, which can be determined by turning the equipment off and on, the user is encouraged to try to correct the interference by one or more of the following measures:

- Reorient or relocate the receiving antenna.
- Increase the separation between the equipment and receiver.
- Connect the equipment into an outlet on a circuit different from that to which the receiver is connected

Declaration of Conformity

The EC Declaration of Conformity is the method by which AMB i.t. declares that the AMB20 system complies with the EMC directive (89/336/EEC) and low voltage directive (73/23/EEC).

The **AMB20 System** consists of:

- AMB20 decoder
- Mains adapter 230 VAC/12 VDC
- AMB20 transponders
- Charger rack

Applicable harmonised EMC standards

EN 55022
EN 50082-1

Class B, Information Technology Equipment
IEC 801-2 Electrostatic Discharge
IEC 801-3 Immunity to Radiated Electromagnetic Fields
IEC 801-4 Electrical Fast Transient, Burst
Low voltage directive

EN 60335

Manufacturer

AMB i.t. B.V.
Herenweg 29A
2105 MB Heemstede
The Netherlands
Tel: ++31 23 529 1893
Fax: ++31 23 529 0156
Homepage: www.amb.nl
E-mail: support@amb.nl

US-Office

AMB i.t. US Inc.
1631 Phoenix Blvd., Suite 11
College Park, GA 30349
U.S.A.
Tel. 770-997-8882
Fax. 770-997-0699
Homepage: www.amb-us.com
E-mail: support@amb-us.com

Authorised signature

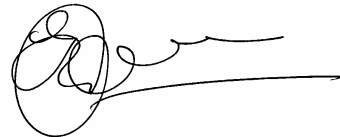

H.Q. van Dooren
General Manager