

Contents

CONTACT INFORMATION	2
1. INTRODUCTION	3
2. INSTALLATION OF THE DETECTION LOOP	4
2.1 Positioning.....	4
2.2 Installation of the detection loop.....	5
2.3 Testing the detection loop installation.....	7
3. TRANSPONDER INSTALLATION/OPERATION	9
3.1 Installation of the transponder.....	9
3.2 Charging instructions.....	12
3.3 Led indication.....	13
3.4 Sleep mode.....	13
3.5 Cleaning instructions.....	14

Appendices

APPENDIX A - USEFUL TOOLS/PARTS/EQUIPMENT.....	17
APPENDIX B - TECHNICAL SPECIFICATIONS.....	18
APPENDIX C - CE AND FCC REGULATIONS.....	19
GUARANTEES & WARRANTIES.....	20

Figures

Figure 1.1 System overview.....	3
Figure 2.1 Detection loop installation overview.....	4
Figure 2.2 Soldering the loop wire end.....	6
Figure 3.1 Transponder placement.....	9
Figure 3.2 Fastening the Direct Powered transponder.....	10
Figure 3.3 Fastening the transponder in the holder.....	11
Figure 3.4 Charging cradle.....	12
Figure 3.5 Led indication.....	13

Contact Information

MYLAPS EMEA Office Haarlem

Haarlem
The Netherlands
Tel: +31 23 529 1893
E-mail: info@mylaps.com

MYLAPS Americas Office

Atlanta
USA
Tel: +1 (678) 816 4000
E-mail:
info.americas@mylaps.com

MYLAPS Japan Office

Tokyo
Japan
Tel: +81 3 5275 4600
Email:
info.japan@mylaps.com

MYLAPS Asia Pacific Office

Sydney
Australia
Tel: +61 (0)2 9546 2606
Email:
info.asia.pacific@mylaps.com

www.mylaps.com



All rights reserved

Copyright © 2004-2010 MYLAPS (formerly AMB i.t.)

This publication has been written with great care. However, the manufacturer cannot be held responsible, either for any errors occurring in this publication or for their consequences.

The sale of products, services of goods governed under this publication are covered by MYLAPS's standard Terms and Conditions of Sales and this product manual is provided solely for informational purposes. This publication is to be used for the standard model of the product of the type given on the cover page.

MYLAPS

Manual: MYLAPS Car&Bike/01-2010

1: Introduction

The MYLAPS Car/Bike Timing System, previously known as the TranX260 system, is designed to time and score competition cars and motorcycles. The signal sent by a MYLAPS Car/Bike transponder is picked up by the detection loop installed in the track surface. The transponder is mounted on a car or motorcycle. The detection loop is connected to the MYLAPS Car/Bike Decoder. The decoder timestamps the received transponder signals and sends this data to a connected computer.

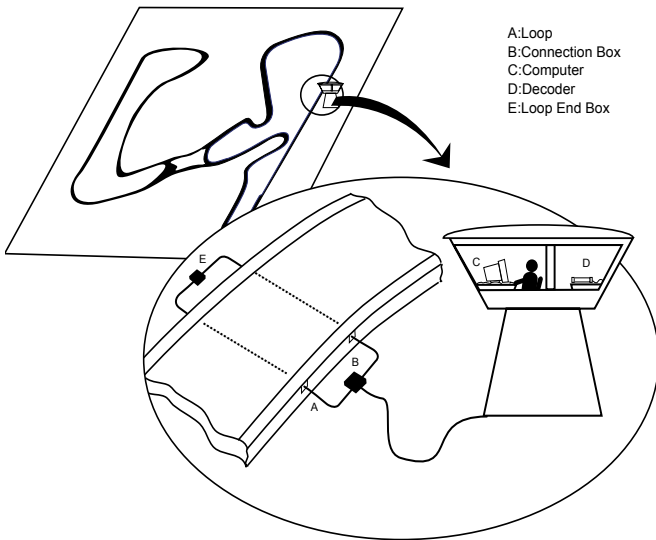

Figure 1.1 System overview

2: Installation of the detection loop

To install the MYLAPS Car/Bike system, one needs to install a detection loop, connect the MYLAPS Car/Bike decoder and mount the MYLAPS transponders to the car/motorcycle. For optimal results, please follow the instructions as described carefully. Appendix B contains a list of useful tools for installing the detection loop.

2.1 Positioning

All wiring of the detection loop must be installed according to the drawing below in order to avoid a serious degradation in the performance of the system.

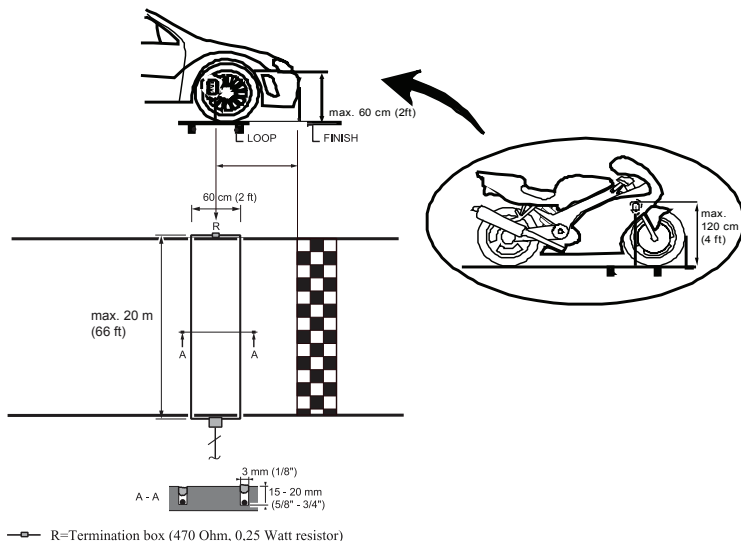

Figure 2.1 Detection loop installation overview

1. The detection loop must be positioned in such a way that the transponder is above the center of the detection loop when the front of the cars/motorcycle crosses the finish line. Make sure cars/motorcycle cannot pass outside the detection loop. Extend the detection loop outside the track if necessary.
2. One loop can be used for a track width of max. 20m (66ft).
3. The detection loop is sensitive to interference, sometimes emitted by nearby cables. When possible, keep other cables 5m (15ft) away. Also, make sure cars/motorcycles or other parts on the track will not get closer than 5m (15ft) to the detection loop, to avoid false inputs.
4. For dirt tracks, the detection loop is best installed in plastic conduits at a maximum of 30cm (1ft) below the surface. The maximum depth should be chosen in a way that the cars/motorcycles cannot dig out the detection loop. However please respect the maximum distance between loop and transponder, which is 60cm (2ft) for cars and 120cm (4ft) for motorcycles.

LEARNED BY EXPERIENCE

When pulling the detection loop wire through the plastic conduit, it is a good idea to pull another non-metal wire through. This wire then can be used to install a new loop wire in case it gets damaged.

2.2 Installation of the detection loop

1. Cut the slots in the track a maximum of 2cm (0.75inch) deep and 60cm (2ft) apart. Make sure the slots are clean and dry. This will ensure a perfect seal when the silicon is applied after the installation of the wiring. Put the wires of the detection loop in the slots and cut the excess length of the detection loop wires.

2. Widen the slot with a chisel where the small connection box of the loop is to be installed. Place the connection box vertically
3. When all wires are installed, put the heat shrinkage sleeve over a detection loop wire end. Then solder the loop wire to the short wire end of the connection box. When soldering the wires together, the solder should flow through the entire connection and not only around it. Now put the shrinkage sleeve over the soldered connection and hold it over a heat source to shrink the sleeve (also see the drawing below). Repeat this procedure for the second wire of the detection loop.
4. Fill the slot with silicone. Before doing this, please test the loop as described in section 2.3. Make sure not to overfill the slots and that the silicone is fully under the surface of the track, otherwise tires may pull out the silicone. If any silicone spills out of the slot, remove the excess silicone by scraping the top with a small piece of cardboard. This also ensures that the silicone is pressed into the slot for a perfect seal.

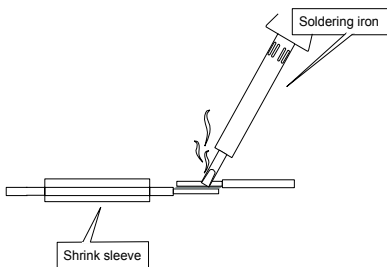

Figure 2.2 Solder the loop wire end

LEARNED BY EXPERIENCE

If you wish, you may pad the slots with backing rod or nylon cord before sealing the slot with silicone. This helps to prevent the excessive use of silicone and is also useful when pulling out the silicone if the detection loop has to be replaced.

Silicone

There is a wide variety of silicone types available in hardware stores; it is important that the right type is used. Silicone that can withstand different temperatures as well as both wet and dry conditions (since weather situations can vary), should be used. If you are unsure, check the specifications of the silicone.

The following types of silicone have been shown to yield lasting results and are recommended by AMB:

- Dow Corning 890SL is a self-leveling silicone kit. It is applied as a liquid and fills the slot completely.
- Purflex is a polyurethane-based silicone that retains its elasticity under a wide range of temperatures.

2.3 Testing the detection loop installation

Once the loop has been installed, it should be tested to ensure that it is functioning correctly. We also recommend repeating the same procedure at the start of each race event. You can determine if your loop is functioning correctly by doing the following tests:

1. Connect the detection loop to the decoder and computer running AMB i.t. timing software (also see the separate decoder manual). Check the background noise, which is updated every 5 seconds in the MYLAPS timing software. The background noise level should be between 0 and 40 points. A higher value may indicate interference by other electrical equipment in the area or a bad loop installation. Try switching off any suspected equipment or

removing nearby objects and check for improvements. Especially at night, short-wave radio transmitters may cause an increased background noise.

2. If a detection loop has been correctly installed, a transponder should be picked up at the same distance along the entire detection loop. To test this, stand at one end of the detection loop about 8m (25ft) away and hold a transponder approximately 120cm (4ft) off the ground. Walk slowly towards the detection loop. You will hear a beep in the headphones attached to the decoder when the transponder is detected. Mark the spot where the transponder was detected. Repeat the process for the middle and other end of the detection loop and do the same coming from the other direction. The detection distance from the loop should be approximately the same for all positions (< 20% variation).
3. Check the signal strengths of the transponders as they are picked up by the system during a test with motorcycles (also see paragraph 3.1 Installation of Transponder). A good loop will yield consistent transponder signal strengths of at least 100 points with a hit rate of at least 10 points. The hit rate may vary depending on the speed of the transponder passings (slower passings yield higher hit counts), but the signal strength should be consistent (< 10 points variation).

3. Transponder Installation/ Operation

3.1 Installation of the transponder

The MYLAPS Car/Bike transponder is available in a battery-powered and Direct Powered (DP) version. The battery-powered transponder can be recharged in a single charger or 34-position charger case.

Positioning the transponder

The position of the rechargeable or DP transponder is identical. The position of the transponder must be identical on all cars or motorcycles competing in the race. Fix the transponder vertically, max. 60cm (2ft) above the track for cars and 120cm (4ft) for motorcycles. Make sure that the transponder has a clear view to the track with no metal or carbon fiber beneath it. Maximum operating temperature should not exceed 50°C (122F).

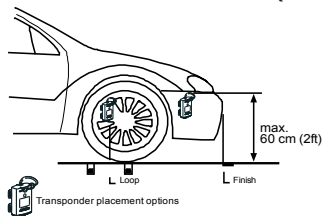

Please note that: The front wheel well is the preferred position.

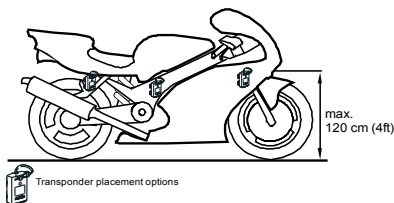

Figure 3.1 Transponder placement

Installation of the Direct Powered transponder

Make sure that the transponder is mounted using pop rivets or screws on all four positions on both sides of the transponder. Use additional tie-wraps for securing the transponder and cable.

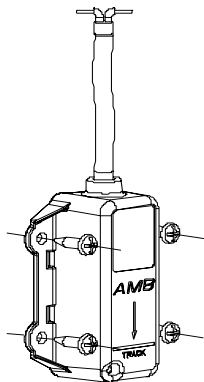

Figure 3.2 Fastening the Direct Powered transponder

Power/ Polarity

Connect the red wire to the +12V (fused circuit) and the black wire to ground (chassis). If the transponder is correctly installed and there is 12V present on the wires, the LED lights continuously.

Installation of the rechargeable transponder

Fix the holder on the car/motorcycle with the fixing rod on top by using tie-wraps or screws. Fasten the transponder in the holder using the supplied fixing pin.

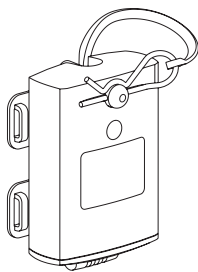
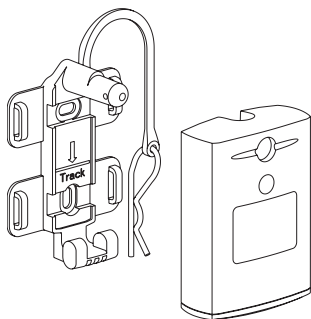

Figure 3.3 Fastening the transponder in the holder

WARNING

A detached transponder can be very dangerous!
Make sure the transponder cannot get detached.
Use additional tie-wraps to secure the pin.

3.2 Charging instructions

Transponders can be charged in an individual charger or in a charger case.

- Plug the power adapter into an electrical outlet and place the transponder on the charging unit.
- The transponder's Led will flash red indicating that the transponder is charging.
- After about 16 hours a steady green Led indicates that the transponder is fully charged.

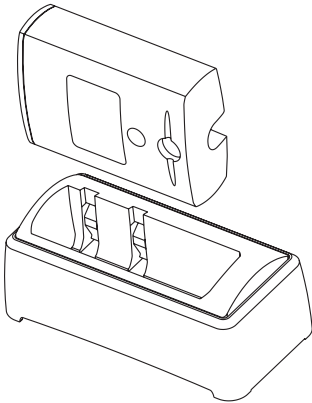

Figure 3.4 : Charging cradle

A full charge yields a minimum of 4 days use. The Led flashing color and pattern indicates the remaining working days of the transponder. See the next paragraph for the complete information.

3.3 Led indication

The Led on the transponder provides the information of the transponder status.

LED Flashing color/pattern	Description
Flashing ...times green	Minimum ... days left before the battery is empty
Flashing red (not in the charger)	Less than 1 day of functioning left
Continuously red	The transponder stops working at any moment, charging is required
No Light	Transponder is discharged
Flashing red (in the charger)	Transponder is charging
Continuous green (in the charger)	Transponder fully charged
No Light (in unplugged charger)	Transponder is in sleep mode

Figure 3.5: Led indication

3.4 Sleep mode

The sleep mode is designed to turn off the transponder's signal and save battery life. It is necessary to use the Sleep mode when travelling by airplane to adhere to airline regulations. While in Sleep mode, the transponder's charge-discharge cycle will last up to 3 times longer.

Switching a transponder into sleep mode

A charged/functioning transponder can be put into a sleep mode by placing it in an unpowered charging cradle or charger case.

Switching the transponder back to normal mode

Normal functioning resumes when the transponder is removed from the cradle or charger case.

3.5 Cleaning instructions

Over the course of time, transponders can become soiled in various ways. Normal dirt can be removed from the transponder with a soft brush and warm clean water up to 50°C. Cleaning electrical contacts: We recommend to spray Isopropyl alcohol on the contacts of the transponder and on the charger. Rub the contacts with ear sticks to clean them on a regular basis.

Caution

MAKE SURE THE TRANSPONDER IS DRY BEFORE CHARGING.

CHARGE YOUR TRANSPONDER ONCE EVERY 3 MONTHS.

DO NOT LEAVE THE TRANSPONDER IN A POWERED CHARGING CRADLE OR CHARGING RACK MORE THAN 24 HOURS.

DO NOT CLEAN TRANSPONDERS WITH AUTOMOTIVE CLEANING PRODUCTS OR OTHER DETERGENTS.

DO NOT USE HIGH PRESSURE WATERGUNS OR OTHER (DISH)WASHING MACHINES TO CLEAN OR RINSE THE TRANSPONDERS.

Appendix A: Usefool tools/parts/ equipment

Useful Tools

- Multi meter (Range at least: 1 Ohm - 1 Mega Ohm)
- Wire cutter / stripper
- BNC Crimp tool for RG 58 & RG 59
- (Butane) Soldering gun
- Blade knife
- Coax stripper
- Screw driver (normal and Phillips)

Useful Spare Parts

- BNC couplers (3 pieces)
- BNC connectors (5 pieces) for yellow coax
- BNC connectors (5 pieces) for brown coax
- Shrink sleeves
- Spare loop (for tracks up to 20 m (65 ft) wide)
- Electrical tape

Additional Tool for new loop installations

- Chalk line to get a straight line on the track surface
- Caulk gun to apply silicone.

Please contact MYLAPS Sports Timing if you would like to receive detailed specifications on any of the above items. You can find our contact details on page 2 of this manual.

Appendix B: Technical Specifications

MYLAPS Car/Bike rechargeable Transponder

Numbers available	: unlimited
Dimensions	: 73x50x22 mm (approx. 2.9x2x0.9inch)
Weight	: 100 g
Housing	: Water- and shockproof
Max. speed	: 260 km/h (160 mph)
Timing Resolution	: 0,002 sec
Temperature range	: 0 - 50 °C (32 - 122 °F)
Operating time	: min. 4 days after full charge
Charge time	: min. 16 hours for full charge
Charge indicator	: LED indicates remaining operating time in days
Signal transfer	: magnetic induction
Transponder position	: max. height cars 60 cm (2ft), max. height motorcycles 120 cm (4ft)

MYLAPS Car/Bike DP Transponder

Numbers available	: unlimited
Dimensions	: 70x52x27 mm (approx. 2.8x2.1x1inch)
Weight	: 179 g inclusive wires 2m (6.6ft)
Housing	: Water- and shockproof
Power consumption	: 10-30 VDC/15 mA
Max. speed	: 260 km/h (160 mph)
Timing Resolution	: 0,002 sec
Temperature range	: 0 - 50 °C (32 - 122 °F)
Signal transfer	: magnetic induction
Transponder position	: max. height 60cm (2ft) cars, max. height 120cm (4ft) motorcycles

Detection Loop

Track width	: max. 20 m (65ft)
Coax to decoder	: max. 100 m (330ft)

MYLAPS Transponder Chargers

Individual charger	: 12 VDC / 0.05 A
34 position charger case	: 12 VDC / 1.0 A

Specifications are subject to change without notice.

Appendix C: CE and FCC Regulations



CE information:

This device complies with the EMC directive 89/336/EEC. A copy of the declaration of conformity can be obtained at:

MYLAPS Sports Timing
Zuiderhoutlaan 4
2012 PJ Haarlem
The Netherlands



FCC information:

This equipment complies with part 15 of the FCC rules. Operation is subject to the following two conditions: (1) This equipment may not cause harmful interference, and (2) this equipment must accept any interference received, including interference that may cause undesired operation.

Guarantees & Warranties

MYLAPS, formerly AMB, warrants that, for a period of three (3) years from the date of shipping the decoders and the MYLAPS MX Rechargeable Power (AMBmx), MYLAPS RC DP (AMBrc DP), MYLAPS KART DP (TranX160 DP), MYLAPS Kart Rechargeable Power (TranX160), MYLAPS Car/Bike DP (TranX260 DP), MYLAPS Car/Bike Rechargeable Power (TranX260), MYLAPS Car/Bike Pro (TranX Pro) transponders covered by this warranty with defects, as determined solely by MYLAPS, caused by faulty materials, workmanship or design will be repaired or replaced, unless such defects were the result of any of the following: shipping; improper installation, maintenance or use; abnormal conditions of operation; attempted modification or repair by the customer or any third party; use of the goods in combination with other items; or an act of God. If repair or replacement of the goods is not possible or economical for MYLAPS, MYLAPS may, at its option, refund the purchase price of the goods or deliver replacement goods at its sole discretion. MYLAPS's liability shall be strictly limited to replacing, repairing or issuing credits at its option.

MYLAPS warrants that, for a period of two (2) years from the date of shipping the ProChip, MYLAPS Kart Fixed Power (TranX140) and the MYLAPS RC Rechargeable Power (AMBrc) transponders covered by this warranty with defects, as determined solely by MYLAPS, caused by faulty materials, workmanship or design will be repaired or replaced, unless such defects were the result of any of the following: shipping; improper installation, maintenance or use; abnormal conditions of operation; attempted modification or repair by the customer or any third party; use of the goods in combination with other items; or an act of God. If repair or replacement of the goods is not possible or economical for MYLAPS, MYLAPS may, at its option, refund the purchase price of the goods or deliver replacement goods at its sole discretion. MYLAPS's liability shall be strictly limited to replacing, repairing or issuing credits at its option.

MYLAPS warrants that, for a period of one (1) year from the date of shipping the MYLAPS Onboard Display kit (TnetX Display Kit) covered by this warranty with defects, as determined solely by MYLAPS, caused by faulty materials, workmanship or design will be repaired or replaced, unless such defects were the result of any of the following: shipping; improper installation, maintenance or use; abnormal conditions of operation; attempted modification or repair by the customer or any third party; use of the goods in combination with other items; or an act of God. If repair or replacement of the goods is not possible or economical for MYLAPS, MYLAPS may, at its option, refund the purchase price of the goods or deliver replacement goods at its sole discretion. MYLAPS's liability shall be strictly limited to replacing, repairing or issuing credits at its option.

MYLAPS warrants that, for a period of one (1) year from the date of shipping, all other goods covered by this warranty with defects, as determined solely by MYLAPS, caused by faulty materials, workmanship or design will be repaired or replaced, unless such defects were the result of any of the following: shipping; improper installation, maintenance or use; abnormal conditions of operation; attempted modification or repair by the customer or any third party; use of the goods in combination with other items; or an act of God. If repair or replacement of the goods is not possible or economical for MYLAPS, MYLAPS may, at its option, refund the purchase price of the goods or deliver replacement goods at its sole discretion. MYLAPS's liability shall be strictly limited to replacing, repairing or issuing credits at its option.

If the requirements set forth above and described under Remedies and Damages are not complied with, our warranty/guarantee shall not apply and we shall be discharged from all liability arising from the supply of defective goods.

EXCEPT AS EXPRESSLY PROVIDED IN THIS SECTION, MYLAPS MAKES NO REPRESENTATIONS OR WARRANTIES OF ANY KIND, NATURE OR DESCRIPTION, EXPRESS OR IMPLIED, INCLUDING WITHOUT LIMITATION, ANY WARRANTY OR MERCHANTABILITY, FITNESS OF THE GOODS FOR ANY PARTICULAR PURPOSE, OR NONINFRINGEMENT, AND MYLAPS HEREBY DISCLAIMS THE SAME.

Remedies and Damages

1. MYLAPS shall not incur any liability under the above warranty unless:
 - i) MYLAPS is promptly notified in writing upon discovery by the customer that such goods do not conform to the warranty, and the appropriate invoice number and date of purchase information is supplied;
 - ii) The alleged defective goods are returned to MYLAPS carriage pre-paid;
 - iii) Examination by MYLAPS of goods shall confirm that the alleged defect exists and has not been caused by unauthorized use (including, without limitation, the use of an AMB decoder with non-MYLAPS hardware) misuse, neglect, method of storage, faulty installation, handling, or by alteration or accident; and
 - iv) With respect to MYLAPS decoders, customer has upgraded the firmware in its decoder within one month after MYLAPS has offered to provide customer with such upgraded firmware.
2. The customer acknowledges that the goods may include certain firmware imbedded therein. MYLAPS hereby grants a license to customer to use the imbedded firmware in an MYLAPS decoder, but only to the extent the decoder is used in connection with MYLAPS hardware. MYLAPS shall have the right to terminate the license immediately upon written notice to customer in case MYLAPS has a reasonable belief that customer at any time has used the MYLAPS decoder in connection with non-AMB hardware. Further, customer may not copy, compile, reverse compile, disassemble, translate, analyze, reverse engineer or attempt to reverse engineer the firmware, except as permitted by applicable law.
3. In addition, customer grants MYLAPS the option to repurchase any MYLAPS decoder if MYLAPS has a reasonable belief that customer has used the MYLAPS decoder in connection with non-MYLAPS hardware. The repurchase price shall be the fair market value on the date MYLAPS provides notice to customer that it intends to repurchase the decoder.

The above mentioned warranty/guarantee is irrespective of any rights granted to the buyer of MYLAPS equipment manufactured or sold by MYLAPS based on the laws of the Netherlands. Any correspondence regarding the above mentioned guarantee must be addressed to MYLAPS:

MYLAPS EMEA OFFICE HAARLEM
Zuiderhoutlaan 4
2012 PJ HAARLEM
THE NETHERLANDS
E-mail: info@mylaps.com
Fax: +31 23 529 0156